

schaerer
swiss coffee competence

The affordable perfection

Easy on your budget, it delivers a full range of impeccable coffee and milk based beverages.

Take it anywhere

Perfect for the office or in a store, you can also install it just about anywhere: no need for a water mains connection thanks to its water tank.



Schaerer Coffee Prime.

*Your prime choice for a flexible, budget-friendly machine
and mobile with impressive quality and output performance.*



Best-in-cup mobility.

Take Coffee Prime just about anywhere, instantly and with no compromise on quality. Easy on your budget, it is also simple to clean and maintain.

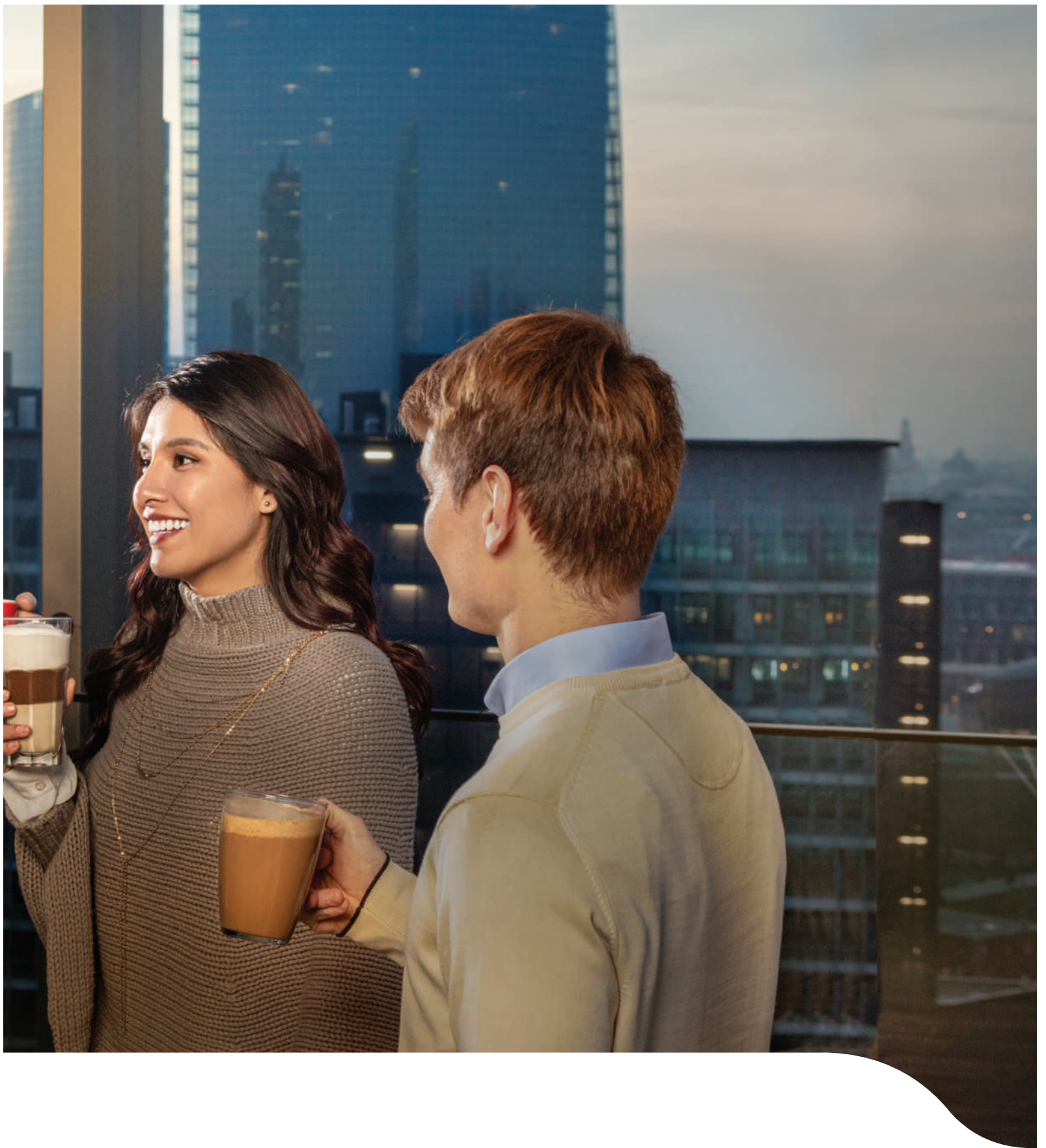

Coffee Prime is all about performance, mobility and easy, automated maintenance and cleaning. It delivers a full range of top quality coffee and milk based beverages with impressive consistency. Wheel it in for an impeccable coffee break in a conference room, break lounge, terrace or rooftop in a flash: with

the integrated fresh water tank, **no need to connect to the water mains, the only requirement is a power connection.** With a daily output capacity of 100 cups, which can be extended to 150 with the optional Powerpack, Coffee Prime is the answer to many hospitality scenarios also thanks to the multiplicity of its configuration options.



Responsible attitude.

Schaerer constantly researches and introduces new ways of minimising the impact on our planet's natural resources, be it innovative technology or a more efficient machine design. In the case of Coffee Prime, compact machine components, a fully insulated boiler and an automatic standby mode when not in use all contribute to **reduced power consumption, with an impact on both the environment and the operating costs.** The innovative NcFoamer concept also greatly reduces the use of chemical detergents, with a further positive effect on the ecosystem.

Ideal for...

Self-service areas in offices, gas stations, universities and hospitals, but also catering operations where portability and flexibility are major assets. Thanks to its compact dimensions and its intuitive, easy use and maintenance, Coffee Prime will naturally fit into most work environment. **Its TouchIT display will help self-serving guests quickly and easily select their preferred beverage, and also effectively feature promotions and ads.** Thanks to the extensive range of configuration options, it can be perfectly and progressively adapted to to your individual requirements.





Quiet, modest, efficient: a trusted team player for all situations, adapting to your evolving requirements.

Starter Configuration.

Get your business up and running with Coffee Prime's comprehensive basic rig. Over time, it will easily adapt to your growing requirements thanks to its great flexibility and simple retrofitting.



The ideal kit.

In standard configuration, Coffee Prime is equipped with **a single insulated boiler** for both coffee and hot water, **a 600 g bean hopper** and a single or double outlet. **A 7" TouchIT screen** user panel, LED

lighting, **a rotating cup platform and drip tray** complete the outfitting. This set is common to both the 1,35 kW and 3kW "Powerpack" versions.

Easy cleaning

Cleaning is automatic and meets all standards of hygiene. Schaerer's innovative **NcFoamer concept dispenses from cleaning the milk system every day: disposable and recyclable, it only needs to be changed every other day, depending on the usage.**



Aquachange and power connection

To help you move Coffee Prime just about anywhere, the **Aquachange mechanism instantly switches water supply from water mains to the tank integrated in the trolley accessory or to an external tank.** All you need to start serving impeccable coffee is a power connection.



Self service solutions

Thanks to its 7" TouchIT touch screen display, Coffee Prime is easy and intuitive to use for anyone, which makes it ideal for self-service also thanks to the connection to the main payment systems. **The screen can display promotions, ads and daily specials.** Easy to supply and fill, its maintenance is equally simple, with automated coffee-system cleaning.

Growing with your business

Coffee Prime's built-in flexibility allows it to adapt to your evolving needs at your own pace, with simple and cost-effective retrofitting without add-ons.



Coffee Prime grows along with your expanding business, naturally adapting to your evolving needs exactly when you need it, with several configuration options and the possibility to retrofit your machine at any time. **Optimise your investment level by selecting only the features you need to**

get started, and expand your machine's capabilities over time. The choice is yours, Coffee Prime's modular concept for grinders and powder systems gives you complete freedom and allows for simple, easy conversion and retrofitting, without the need for costly add-ons.

Flexible, modular and engineered for easy retrofitting.

Second grinder and hopper

Powdered milk

Second boiler

Powerpack: more power, two boilers, larger containers

Fresh milk

Double outlet



Offer extensive variety and consistent best in cup quality.

Offer up to 40 different beverages, prepared to your own specifications from freshly-ground coffee beans, fresh or powdered milk or chocolate powder. Opt for a second outlet exclusively dedicated to hot water for teas and soups, avoiding mixing of flavours, make your own coffee blend from the two grinders or offer lactose-free beverages: numerous possibilities to deliver a consistent, top quality and intensely satisfying coffee experience.

Maximum flexibility components.

Decide whether your initial Coffee Prime setup needs **fresh or powdered milk**, have an **under-unit or side cooling system**, go for a **second grinder or boiler**, or both, provide a **three-size cup dispenser**, or add your preferred **payment system**.

Powerpack, power coffee.

With an average daily output capacity of 100 cups for the basic version, Coffee Prime ranks as solid performer. **For more fire-power, you should opt for the Powerpack, which can boost capacity**, especially for extra-large milk-based drinks. Delivering a mighty 3kW (or 2kW for Switzerland) for each boiler and managing larger quantities at a faster pace thanks to larger containers, this feature can increase **output to up to 150 daily cups**.

Standard equipment, options, accessories.

STANDARD EQUIPMENT:



Intuitive user interface

The 7" TouchIT user interface panel is easy and intuitive to use for anyone, which makes it **ideal for self service**.



Single and double outlets

Single outlet on 1.35kW version, double outlet on 3kW (2kW for Switzerland) "Powerpack" version.



Drip-tray and cup platform

Chromium nickel steel, **dishwasher proof tray** for perfectly dry cups. Manually adjustable cup platform to fit cup size.

OPTIONAL FEATURES:



Large powder container

Add extra capacity (**1400 g / 2000 ml**) for consistent performance and increased autonomy, especially for large, powder-based beverages.



Milk system

Dual powdered/fresh milk system, **also for lactose-free powders**.



Large bean hopper

Fit a larger capacity **1200 g** bean hopper for increased output.



Second grinder

The two grinders can be combined with two 600 g bean hoppers, **with the possibility to blend the two coffee grounds**.

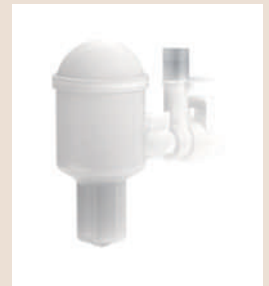

NcFoamer

This milk system does not require cleaning as it is **disposable and recyclable**, and only needs replacing every other day.



Schaerer Coffee Link: your digital intelligence

Schaerer Coffee Link is a digital service platform providing a powerful, real-time tool for **the monitoring and the optimisation of your coffee operation**.

OPTIONAL FEATURES:



Aquachange

Conversion of drinking water tank (5.2 l) to **mains water supply possible** by in-house technician.

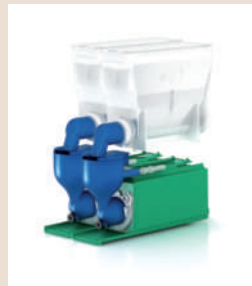

Powder container

Add a powder container **for chocolate, powdered milk or other ingredients**, or fit a twin topping container to store two different toppings.

ACCESSORIES:

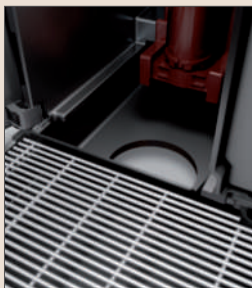

Under-counter grounds disposal

Expands ground-cakes disposal capacity, and machine autonomy, whilst **freeing up counter space**.



Under-machine cooling unit

To help saving counter-space. **9.5 l** capacity.



Three-size cup dispenser

Accommodates 60-74 / 75-82 / 83-90 mm diameter cups. **Also features 3 containers for extras such as stirrers, sugar, etc.**



Payment systems

All MDB-standard payment systems. Card reader, coin changer and other systems **can be easily connected to the machine.**



Side cooling unit (fridge)

Including compressor. Allows storage and cooling of **two-gallon containers or a single 10-litre container** of milk.

Configuration and technical data.

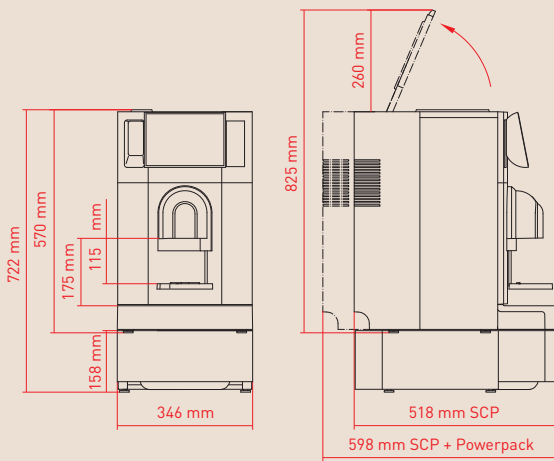

Schaerer Coffee Prime with Powerpack and under-machine unit

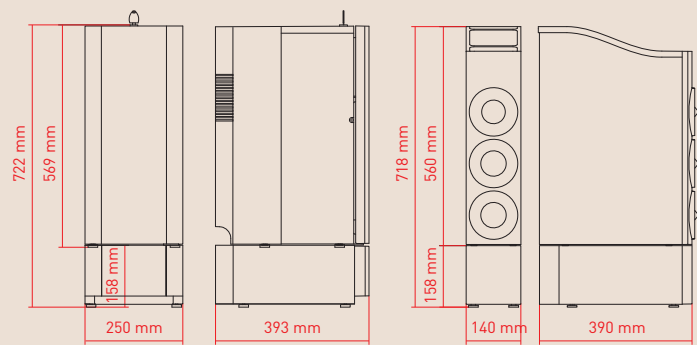

Side cooling unit with base

Cup dispenser with base

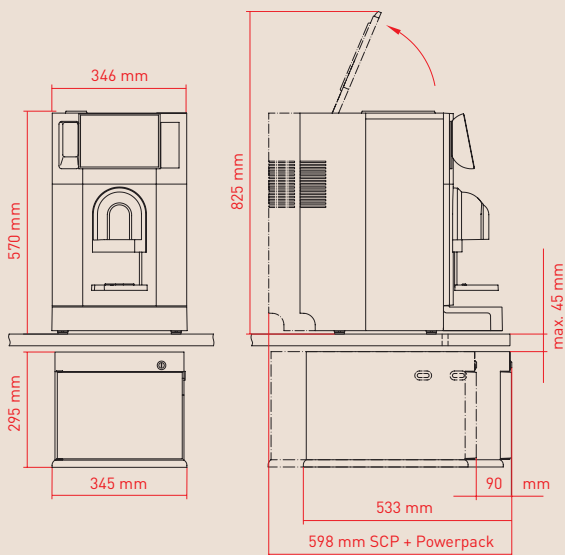

Under-machine cooling unit under counter

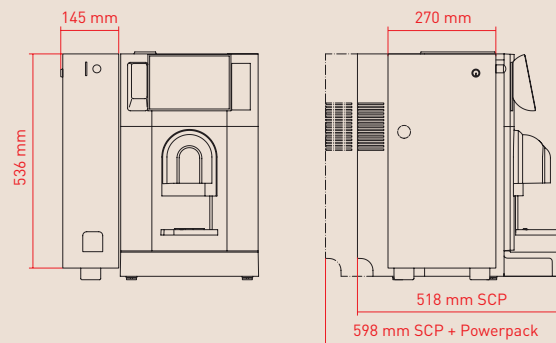

Coin changers

Kategorie	Ausstattung und Optionen	Schaerer Coffee Prime 1.35 kW	Schaerer Coffee Prime with Powerpack 3 kW [2 kW (CH)]
Output per day	Recommended for an average daily requirement of	100	150
Output per hour	Espresso	120	120
	Coffee	85	95
	Cappuccino (200ml)	90	110
	Cappuccino (320ml)	60	90
	Cappuccino (470ml)	35	60
Range of beverages	Ristretto	s	s
	Espresso	s	s
	Coffee	s	s
	Milk coffee/bowl	o	o
	Cappuccino	o	o
	Latte macchiato	o	o
	Chociatto	o	o
	Hot milk foam	o	o
	Hot water	s	s
Operation and dispensing	Instant beverages (e.g. tea, soup, etc.)	o	o
	Self-service mode	s	s
	Number of beverages possible (programmable)	40	40
	Cup platform (manually adjustable)	s	s
	Single outlet (outlet height manually adjustable 115-175mm)	s	o
	Doublet outlet	o	s
	Touch Screen 7"	s	s
Grinders and containers	Hot water outlet central		
	1 grinder	s	s
	2 grinders	o	o
	Bean hopper [g]	600	600
Boilers	Large bean hopper [g]	1200	1200
	Hot water boiler for coffee	s	s
Milk systems and cooling units	Steam boiler	o	o
	Milk Smart (MS)	o	o
	Side cooling unit	o	o
	Under-machine cooling unit	o	o
Powder system	Cup & Cool	o	o
	Powder Container [g]	1400	1400
	Twin Powder container [g]	2x700	2x700
	Topping [1x topping powder], e.g. milk powder	o	o
	Chocolate [1x chocolate powder]	o	o
	Chocolate/Topping [1x chocolate and 1x topping powder]	o	o
	Twin Topping [2x topping powder]	o	o
	Chocolate topping [2x chocolate powder]	o	o
Other options	Instant powder	o	o
	Brewing accelerator	o	o
	Grounds container [coffee grounds cake]	40	40
	Undercounter grounds disposal	o	o
	Base + grounds container [coffee grounds cake]	o [100]	o [100]
Payment system	Lighting	o	o
	Payment systems (MDB-S/DIVA2 Max)	o	o
	Coin and token tester	o	o
	Coin changers	o	o
Colours	Schaerer Coffee Link	o	o
	Titanium silver	s	s
Dimensions and weight	Black	s	s
	Width [mm]	346	346
	Depth [mm]	518	598
	Height [mm]	570	570
Energy supply and power	Weight [kg] [net]	25	33
	1L, N, PE: 220-240 V- 50/60 Hz	2000-2400 kW/10-16A/3 x 1mm ²	2800-3300 kW/16A/3 x 1,5mm ² 1800-2300 kW/10-16 A/ 3 x 1 mm ²
	1L, N, PE: 100 V- 50/60 Hz	1350kW/15 A/ 3 x 1,5mm ² or 1350 kW/15 A/ 3 x 16 AWG	570 25
Water supply and disposal	Internal fresh water tank	s	s
	Mains water supply	s	s
	Waste water outlet	o	o
	Monitored waste water tank	o	o
	Aquachange	s	s

s: Standard
o: Option



We love it *your way.*



Coffee competence

Our long established Coffee Competence is at your service, just call on us for any advice.



Flexibility

We support your business through our flexible offer, because we love it your way.



Swiss

As a Swiss technology company, we commit to impeccable quality and performance.

Headquarters

Schaerer Ltd.

Allmendweg 8
4528 Zuchwil
Switzerland
info@schaerer.com

Discover the worldwide Schaerer network and our comprehensive coffee expertise no matter where you are!

With subsidiaries and partners in more than 70 countries in Europe, America, Africa, Asia and the Pacific region.

Find a contact near you:
[schaerer.com](https://www.schaerer.com)

Schaerer – a Groupe SEB Company

Version 09.2020 – Subject to change.

